

NOTES:

- 1) LABEL HARNESS WITH PART NUMBER AND REVISION.
- 2) LABEL TERMINALS AS SHOWN.
- 3) SOLDER DRAIN OF ITEM #3 TO ITEM #10, COVER WITH ITEM #13.
- 4) SOLDER DRAIN OF ITEM #5 TO ITEM #11, COVER WITH ITEM #13.
- 5) TYPICAL STRIP LENGTH IS 4 INCHES.

SEE NOTE 2

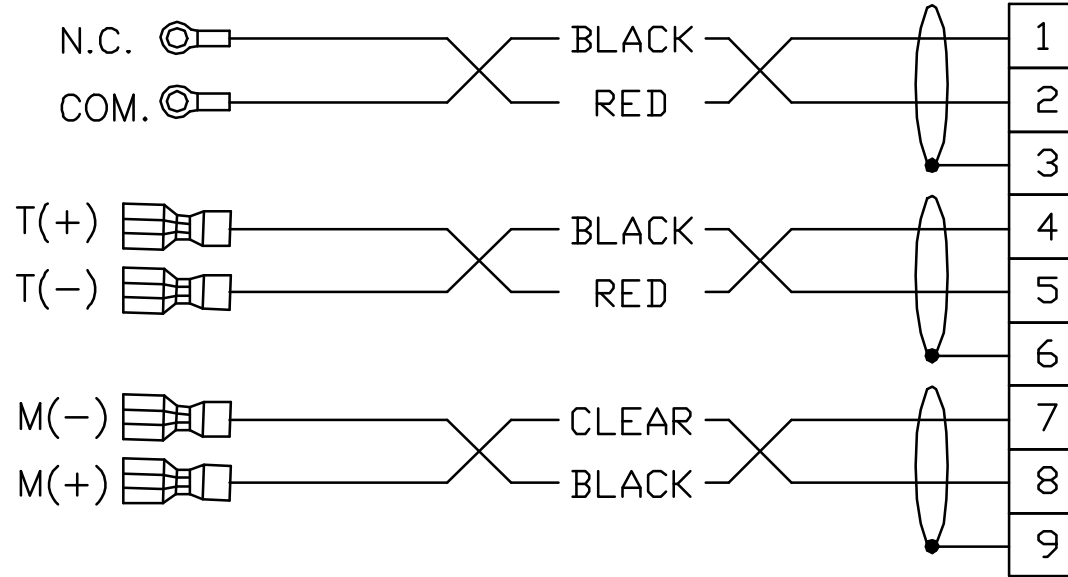

QTY.	PART NUMBER	ITEM DESCRIPTION	ITEM
6 IN	406-6481-002	SHRINK TUBE, 1/8" DIA. BLACK	13
2 IN	406-6481-005	SHRINK TUBE, 3/8" DIA. BLACK	12
2 IN	406-2005-020	WIRE, 18 AWG BLACK	11
4 IN	406-1687-010	WIRE, 24 AWG BLACK	10
3 PC	406-0801-132	TERMINAL, MALE CRIMP 0.093 14-20 AWG	9
6 PC	406-0801-139	TERMINAL, MALE CRIMP 0.093 22-24 AWG	8
1 PC	406-0801-138	PLUG, STD. 0.093 9 POSITION	7
2 PC	406-7001-025	RING TONGUE, #6 26-22 AWG	6
9 IN	406-1242-012	CABLE, 1 PAIR TWISTED 16 AWG	5
2 PC	406-7001-077	QUICK CONNECT, .187 X .020 FEMALE 16-14 AWG	4
29 IN	406-1242-013	CABLE, 1 PAIR TWISTED 24 AWG	3
4 IN	406-6481-003	SHRINK TUBE, 3/16" DIA. BLACK	2
2 PC	406-7001-078	QUICK CONNECT, .187 X .020 FEMALE 26-24 AWG	1

PARTS LIST

REV	P.I.N. NO.	REVISION DESCRIPTION	REV BY	DATE	CHK BY	DATE	APP BY	DATE	DF
D	12790	L.S. LABEL WAS N.O.	F	8/2/93					
C	12760	SWAPPED MOTOR LEAD LABELS	D	7/29/93	K	7/23/93			
B	12609	WAS WIRING SIDE VIEW	K	3/30/93	M	3/21/93	D	4/6/93	
A	12543	RELEASE	K	02/01/93	M	02/02/93	D	02/28/93	

SURFACE TREATMENT ~	EXCEPT AS NOTED: ALL DIMENSIONS IN INCHES TOLERANCE DECIMAL .0 ? .0300 .00 ? .0150 .000 ? .0050 0.000 ? .0005	HURCO MANUFACTURING COMPANY, INC. INDIANAPOLIS, IN U.S.A.					
HEAT TREATMENT ~	ANGULAR ? 0230' BREAK ALL SHARP EDGES	DESCRIPTION HARNESS, AB7 INTERNAL GAUGE S6/S7/S8					
FIRST USED ON AUTOBEND 7	THIRD ANGLE PROJECTION 	DRAWN KLP	DATE 02/01/93	CHECKED MFC	DATE 02/02/93	APPROVED DAB	DATE 2/25/93
		SCALE NONE	SIZE C	DRAWING 423-0204-001		SHT. 1	REV. 1
		UNIT OF MEAS PC					

CN
AB498